

THIS DRAWING IS UNPUBLISHED.

RELEASED FOR PUBLICATION

AUG ,2006.

© COPYRIGHT - BY TYCO ELECTRONICS CORPORATION. ALL RIGHTS RESERVED.

LOC	DIST	REVISIONS			
P	LTR	DESCRIPTION	DATE	DWN	APVD
		SEE SHEET 1.			

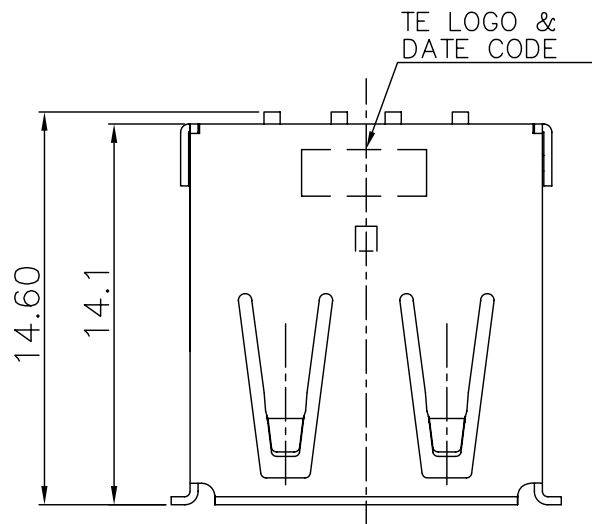

NOTES:

- MATERIAL:
HOUSING: THERMOPLASTIC HIGH TEMP., WITH 30% GLASS FIBER, UL 94V-0 RATED, COLOR: BLACK.
CONTACTS: PHOSPHOR BRONZE, THICKNESS=0.25mm.
SHIELD: BRASS, THICKNESS=0.30mm.
- FINISH :
CONTACT : 30μ" MIN. GOLD PLATED ON CONTACT AREA.
150μ" MIN. BRIGHT TIN PLATING ON SOLDERTAILS
50μ" MIN. NICKEL UNDERPLATED OVERALL.
SHIELD : 40μ" MIN. NICKEL PLATING OVER 40μ" MIN. Cu.
- REFLOW SOLDER CAPABLE TO 260°C PER TE SPEC109-201, CONDITION B.

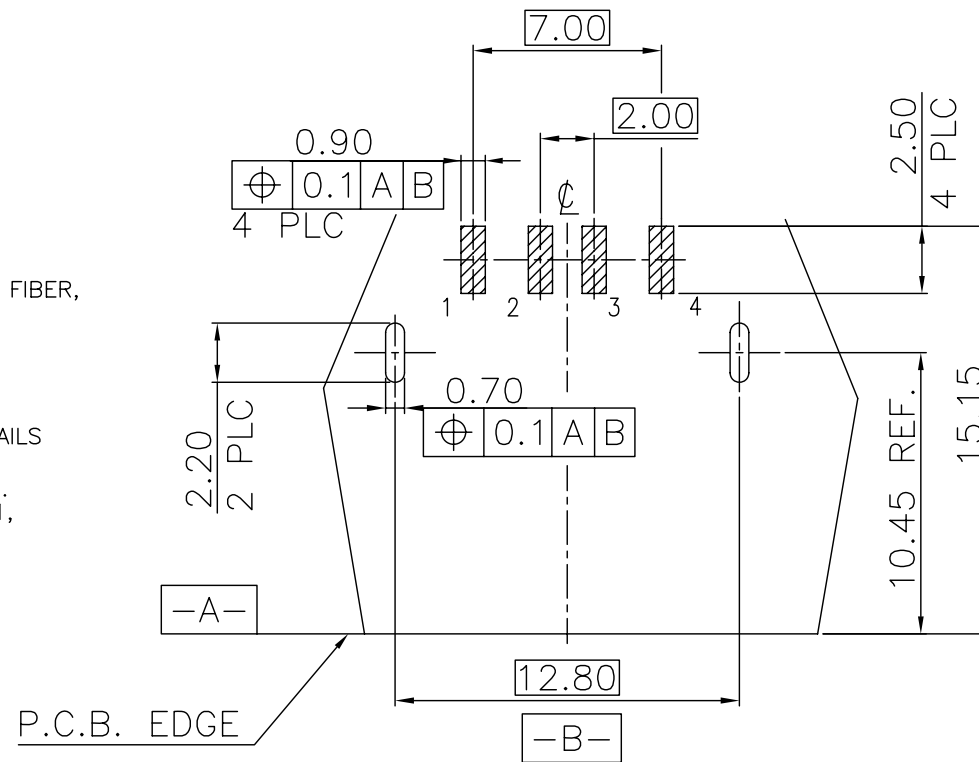
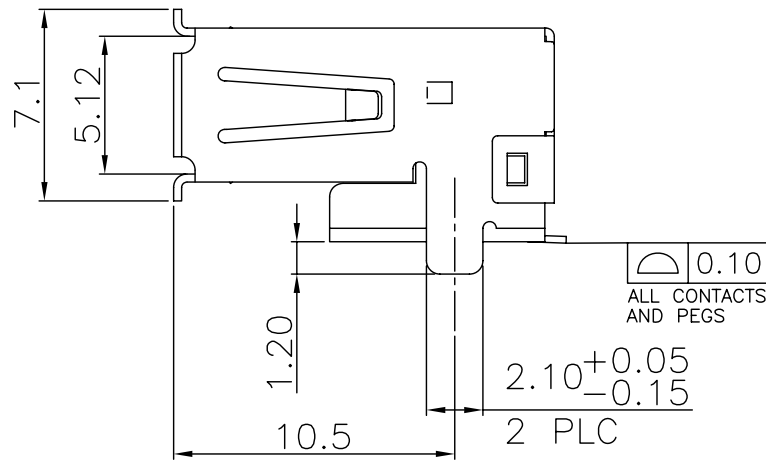
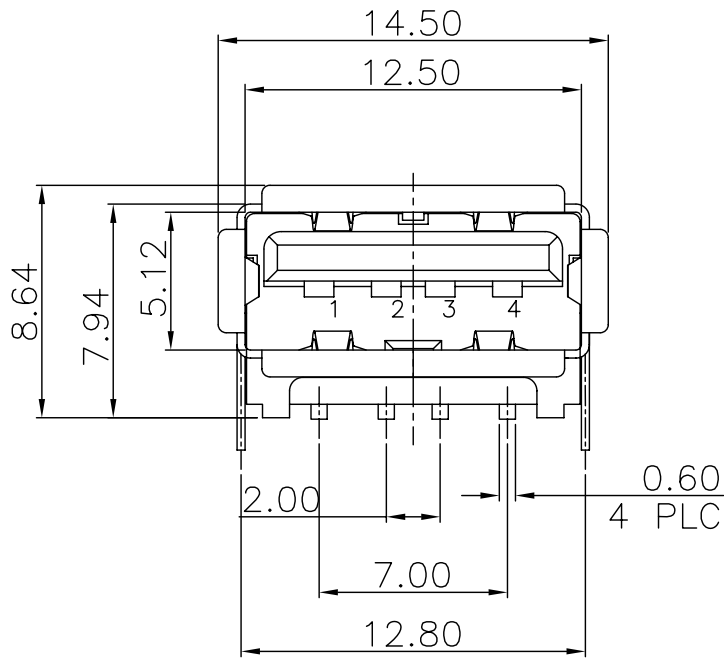

RECOMMENDED PCB LAYOUT (THICKNESS 1.6mm)
(TOP VIEW) TOLERANCES: ±0.05

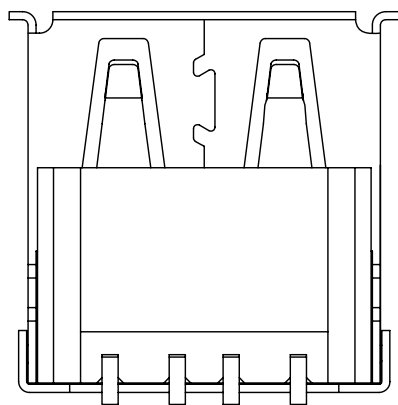

2-1734082-1
PART NUMBER

THIS DRAWING IS A CONTROLLED DOCUMENT.		DWN	Tyco Electronics Corporation Taipei, Taiwan		
DIMENSIONS: MM		CHK	NAME		
TOLERANCES UNLESS OTHERWISE SPECIFIED:		APVD	USB CON, RCPT, ASS'Y, R/A SMT, A TYPE		
0 PLC ± -		PRODUCT SPEC	SIZE	CAGE CODE	DRAWING NO
1 PLC ± -		APPLICATION SPEC	A3	00779	C=1734082
2 PLC ± -		WEIGHT	RESTRICTED TO		
3 PLC ± -		CUSTOMER DRAWING	-		
4 PLC ± -		SCALE	SHEET 2 OF 4		
ANGLES ± -		REV	A		
FINISH					

THIS DRAWING IS UNPUBLISHED. RELEASED FOR PUBLICATION AUG ,2006.

© COPYRIGHT BY TYCO ELECTRONICS CORPORATION. ALL RIGHTS RESERVED.

LOC	DIST	REVISIONS			
P	LTR	DESCRIPTION	DATE	DWN	APVD
		SEE SHEET 1.			

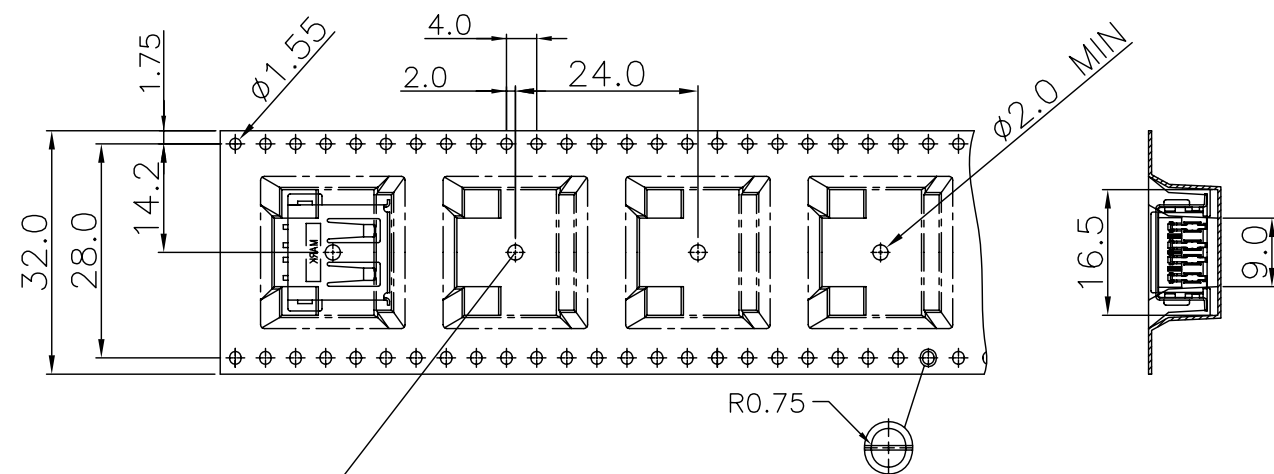

- NOTES:
- MATERIAL:
REEL: PS.
CARRIER: PS.
COVER TAPE: PBT.
 - DIMENSION:
TRAY REEL: $\phi 330\text{mm} \times 37.1\text{mm}$.
SHIPPING CARTON: L=350mm, W=350mm, H=200mm.
 - QUANTITY:
300 PCS/ REEL.
5 REELS/ SHIPPING CARTON (TOTAL: 1500 PCS).
 - WEIGHT:
4.1 NET WEIGHT: 0.55KG/REEL, 2.73KG/SHIPPING CARTON.
4.2 GROSS WEIGHT: 0.87KG/REEL, 5.36KG/SHIPPING CARTON.
 - PEELING RESISTANCE: 20gf TO 130gf.
 - PEELING SPEED: 300MM/MIN.

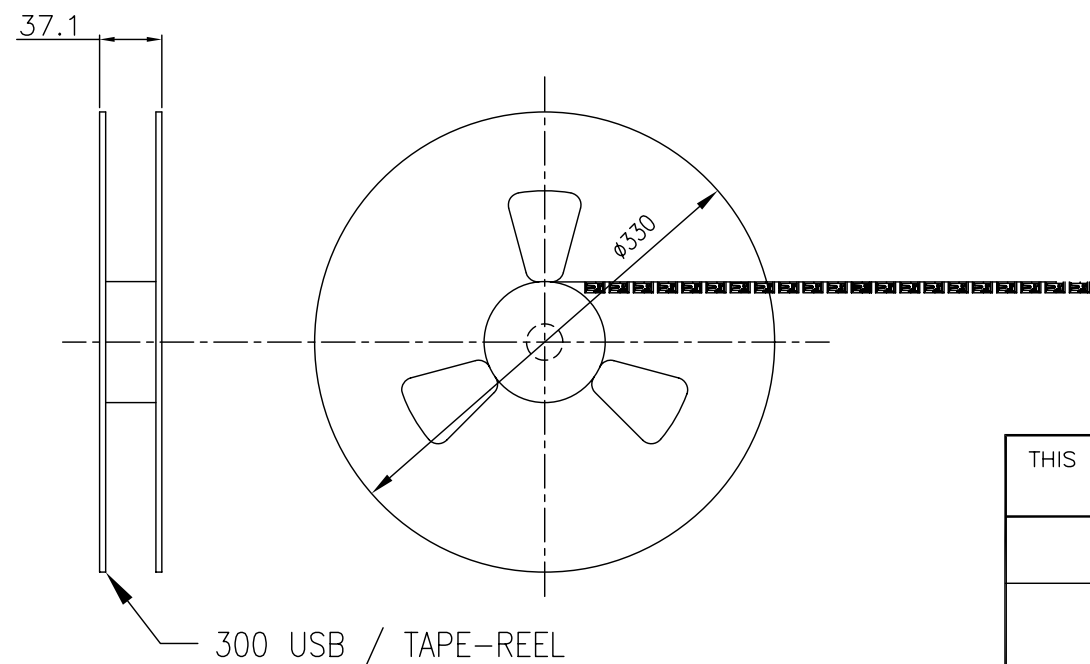
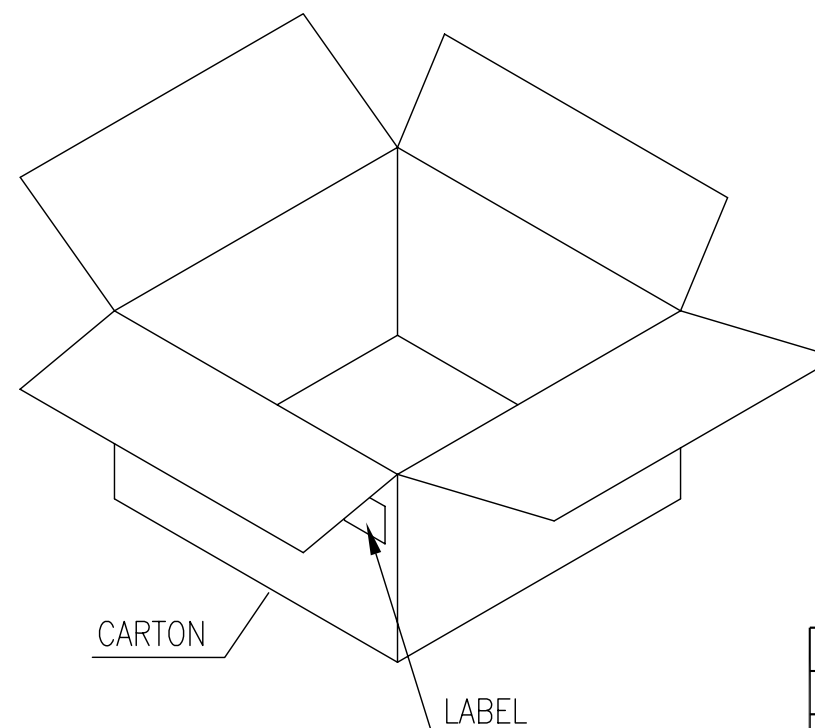
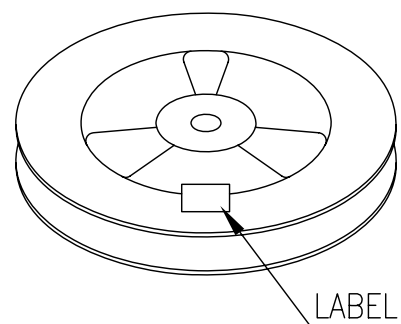
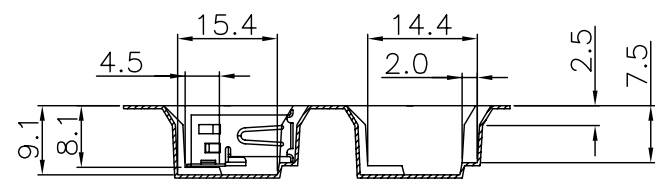
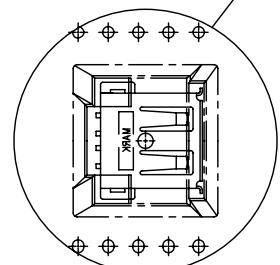

1-1734082-2
1-1734082-1
1734082-2
1734082-1
PART NUMBER

THIS DRAWING IS A CONTROLLED DOCUMENT.		DWN	Tyco Electronics Corporation Taipei, Taiwan		
DIMENSIONS: MM		CHK	NAME		
TOLERANCES UNLESS OTHERWISE SPECIFIED:		APVD	USB CON, RCPT, ASS'Y, R/A SMT, A TYPE		
0 PLC ± -		PRODUCT SPEC	SIZE		
1 PLC ± -		APPLICATION SPEC	CAGE CODE	DRAWING NO	RESTRICTED TO
2 PLC ± -		WEIGHT	A3	00779	1734082
3 PLC ± -		CUSTOMER DRAWING	SCALE		
4 PLC ± -			SHEET 3 of 4		
ANGLES ± -			REV A		
FINISH					

THIS DRAWING IS UNPUBLISHED. RELEASED FOR PUBLICATION AUG ,2006.

© COPYRIGHT BY TYCO ELECTRONICS CORPORATION. ALL RIGHTS RESERVED.

LOC	DIST	REVISIONS					
DW		P	LTR	DESCRIPTION	DATE	DWN	APVD
				SEE SHEET 1.			

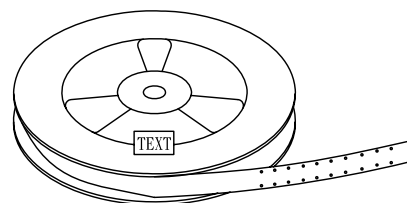
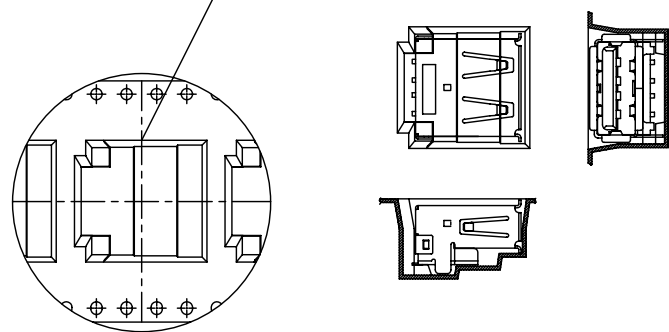
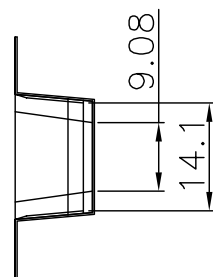
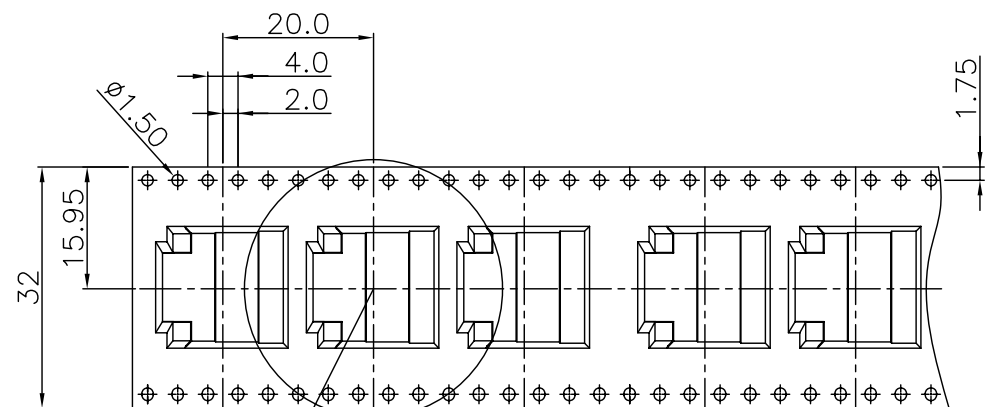

NOTES:

- MATERIAL:
REEL: PS.
CARRIER: PS.
COVER TAPE: PBT.
- DIMENSION
REEL: $\phi 330\text{mm} \times 37.1\text{mm}$
SHIPPING CARTON: L=350mm, W=350mm, H=350mm
- QUANTITY:
300 PCS/REEL
9 REELS /SHIPPING CARTON (TOTAL: 2700 PCS).
- WEIGHT:
4.1 NET WEIGHT: 0.66KG/REEL, 5.94KG/SHIPPING CARTON.
4.2 GROSS WEIGHT: 1.22KG/REEL, 12KG/SHIPPING CARTON.
- PEELING RESISTANCE: 20gf TO 130gf.
- PEELING SPEED: 300MM/MIN.

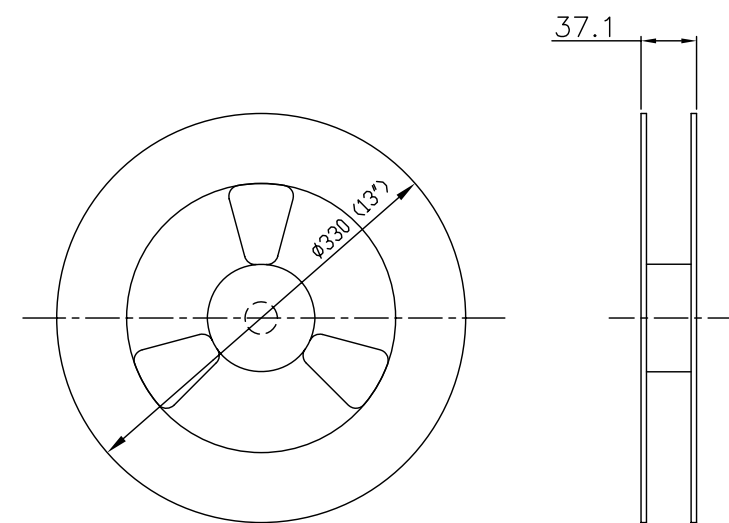
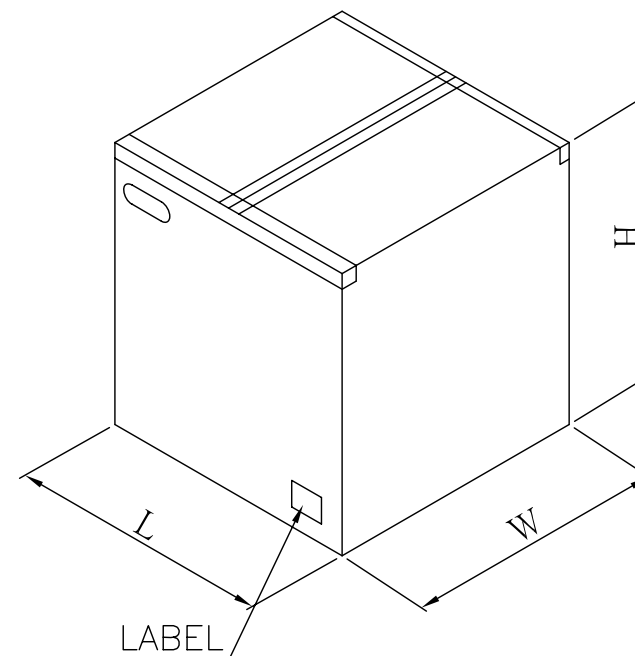
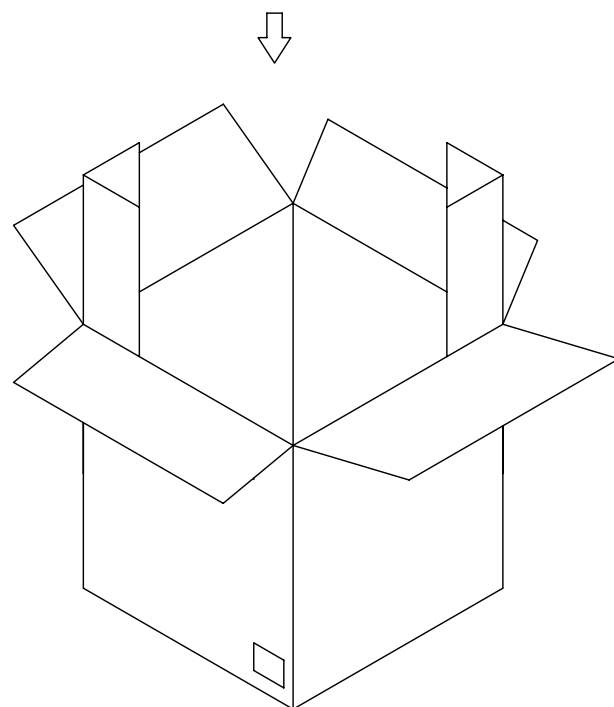
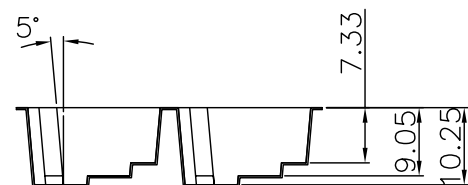

2-1734082-1
PART NUMBER

THIS DRAWING IS A CONTROLLED DOCUMENT.		DWN	Tyco Electronics Corporation Taipei, Taiwan		
DIMENSIONS: MM		CHK	NAME		
TOLERANCES UNLESS OTHERWISE SPECIFIED:		APVD	USB CON, RCPT, ASS'Y, R/A SMT, A TYPE		
0 PLC	± -	PRODUCT SPEC	SIZE	CAGE CODE	DRAWING NO
1 PLC	± -	APPLICATION SPEC	A3	00779	C=1734082
2 PLC	± -	WEIGHT	RESTRICTED TO		
3 PLC	± -	CUSTOMER DRAWING	SCALE		
4 PLC	± -		SHEET 4 of 4		
ANGLES	± -		REV A		
MATERIAL	FINISH				